

AB-48 DVD Applications

DV-255W-KA5Q1565 – 255 Watts

Application	FPS Device	Input Voltage Range	Rated Output Power	Output Voltage (Rated Current)
DVD Receiver	KA5Q1565RF	85–265 Vac	200W (average) 255W (peak)	4.5V (0.1A) – VFD 34V (1.0A) 27.5V (average: 4.0A / peak: 6A) 12V (2.0A) 8V (2.5A) 5V (1.4A) 3.3V (1.4A)

Features

- High efficiency (>83%) and low EMI through Quasi-resonant operation
- Various Protection functions against over load, over voltage, over current and over temperature.

1. Schematic Diagram

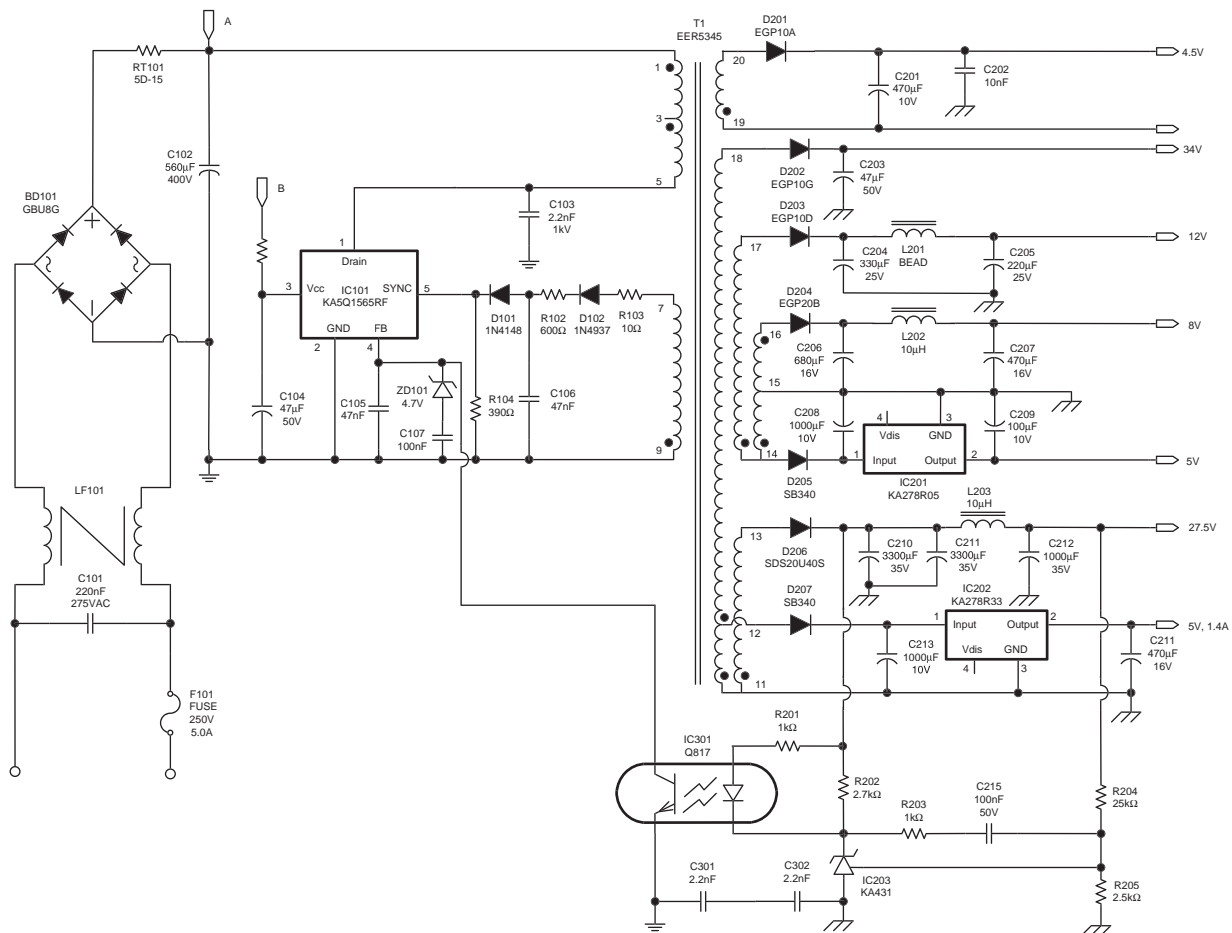

2. Transformer

2.1. Transformer Schematic Diagram

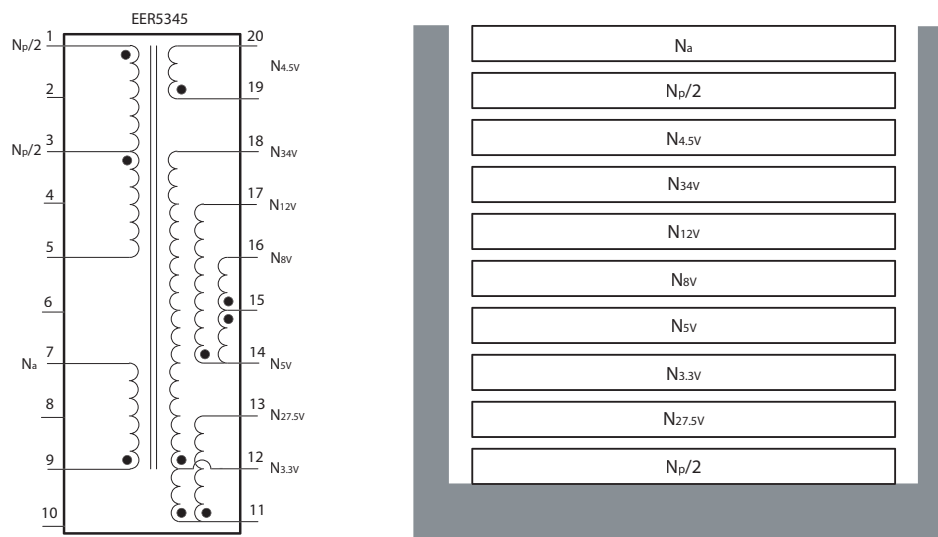

2.2. Winding Specification

	Pin (S → F)	Wire	Turns	Winding Method
$N_p/2$	1 → 3	$0.6\Phi \times 4$	16	Solenoid winding
Insulation: Polyester Tape $t = 0.050\text{mm}$, 3 Layers				
$N_{27.5V}$	11 → 13	Copper Plate	6	
Insulation: Polyester Tape $t = 0.050\text{mm}$, 1 Layers				
$N_{3.3V}$	11 → 12	$0.4\Phi \times 3$	1	Space winding
Insulation: Polyester Tape $t = 0.050\text{mm}$, 1 Layers				
N_{5V}	15 → 14	$0.4\Phi \times 3$	2	Space winding
Insulation: Polyester Tape $t = 0.050\text{mm}$, 1 Layers				
N_{8V}	15 → 16	$0.4\Phi \times 2$	2	Space winding
Insulation: Polyester Tape $t = 0.050\text{mm}$, 1 Layers				
N_{12V}	14 → 17	$0.3\Phi \times 1$	1	Space winding
Insulation: Polyester Tape $t = 0.050\text{mm}$, 1 Layers				
N_{34V}	12 → 18	$0.3\Phi \times 1$	6	Solenoid winding
Insulation: Polyester Tape $t = 0.050\text{mm}$, 1 Layers				
$N_{4.5V}$	20 → 19	$0.3\Phi \times 1$	1	Solenoid winding
Insulation: Polyester Tape $t = 0.050\text{mm}$, 3 Layers				
$N_p/2$	3 → 5	$0.6\Phi \times 4$	15	Solenoid winding
Insulation: Polyester Tape $t = 0.050\text{mm}$, 2 Layers				
N_a	9 → 7	$0.4\Phi \times 1$	5	Solenoid winding
Outer Insulation: Polyester Tape $t = 0.050\text{mm}$, 3 Layers				

Core: EER5345 ($A_e = 318.44 \text{ mm}^2$)

Bobbin: EER5345

2.3. Electrical Characteristics

	Pin	Spec.	Remark
Inductance	1–5	270 μH	1 kHz, 1V
Leakage	1–5	10 μH	Short all other pins

TRADEMARKS

The following are registered and unregistered trademarks Fairchild Semiconductor owns or is authorized to use and is not intended to be an exhaustive list of all such trademarks.

ACEx™	FAST®	IntelliMAX™	POP™	SPM™
ActiveArray™	FASTr™	ISOPLANAR™	Power247™	Stealth™
Bottomless™	FPS™	LittleFET™	PowerEdge™	SuperFET™
CoolFET™	FRFET™	MICROCOUPLER™	PowerSaver™	SuperSOT™-3
CROSSVOLT™	GlobalOptoisolator™	MicroFET™	PowerTrench®	SuperSOT™-6
DOME™	GTO™	MicroPak™	QFET®	SuperSOT™-8
EcoSPARK™	HiSeC™	MICROWIRE™	QS™	SyncFET™
E ² C MOS™	PC™	MSX™	QT Optoelectronics™	TinyLogic®
EnSigna™	i-Lo™	MSXPro™	Quiet Series™	TINYOPTO™
FACT™	ImpliedDisconnect™	OCX™	RapidConfigure™	TruTranslation™
FACT Quiet Series™		OCXPro™	RapidConnect™	UHC™
Across the board. Around the world.™		OPTOLOGIC®	µSerDes™	UltraFET®
The Power Franchise®		OPTOPLANAR™	SILENT SWITCHER®	UniFET™
Programmable Active Droop™		PACMAN™	SMART START™	VCX™

DISCLAIMER

FAIRCHILD SEMICONDUCTOR RESERVES THE RIGHT TO MAKE CHANGES WITHOUT FURTHER NOTICE TO ANY PRODUCTS HEREIN TO IMPROVE RELIABILITY, FUNCTION OR DESIGN. FAIRCHILD DOES NOT ASSUME ANY LIABILITY ARISING OUT OF THE APPLICATION OR USE OF ANY PRODUCT OR CIRCUIT DESCRIBED HEREIN; NEITHER DOES IT CONVEY ANY LICENSE UNDER ITS PATENT RIGHTS, NOR THE RIGHTS OF OTHERS.

LIFE SUPPORT POLICY

FAIRCHILD'S PRODUCTS ARE NOT AUTHORIZED FOR USE AS CRITICAL COMPONENTS IN LIFE SUPPORT DEVICES OR SYSTEMS WITHOUT THE EXPRESS WRITTEN APPROVAL OF FAIRCHILD SEMICONDUCTOR CORPORATION. As used herein:

1. Life support devices or systems are devices or systems which, (a) are intended for surgical implant into the body, or (b) support or sustain life, or (c) whose failure to perform when properly used in accordance with instructions for use provided in the labeling, can be reasonably expected to result in significant injury to the user.
2. A critical component is any component of a life support device or system whose failure to perform can be reasonably expected to cause the failure of the life support device or system, or to affect its safety or effectiveness.

PRODUCT STATUS DEFINITIONS

Definition of Terms

Datasheet Identification	Product Status	Definition
Advance Information	Formative or In Design	This datasheet contains the design specifications for product development. Specifications may change in any manner without notice.
Preliminary	First Production	This datasheet contains preliminary data, and supplementary data will be published at a later date. Fairchild Semiconductor reserves the right to make changes at any time without notice in order to improve design.
No Identification Needed	Full Production	This datasheet contains final specifications. Fairchild Semiconductor reserves the right to make changes at any time without notice in order to improve design.
Obsolete	Not In Production	This datasheet contains specifications on a product that has been discontinued by Fairchild semiconductor. The datasheet is printed for reference information only.

Rev. 115