

AB-36 CRT Monitors

CM-64W-FS8S0765 - 64 Watts

| Application | FPS Device | Input Voltage Range | Rated Output Power | Output Voltage (Rated Current) |
|--------------|-------------|---------------------|--------------------|--|
| CRT Monitors | FS8S0765RCB | 85–265 Vac | 64W | 80V (0.15A) 50V (0.70A) 14V (0.8A) -14V (0.3A) 6.5V (0.3A) |

Features

- Protection functions against over load, over voltage, over current and over temperature.
- Primary side regulation for a cost reduction.

1. Schematic Diagram

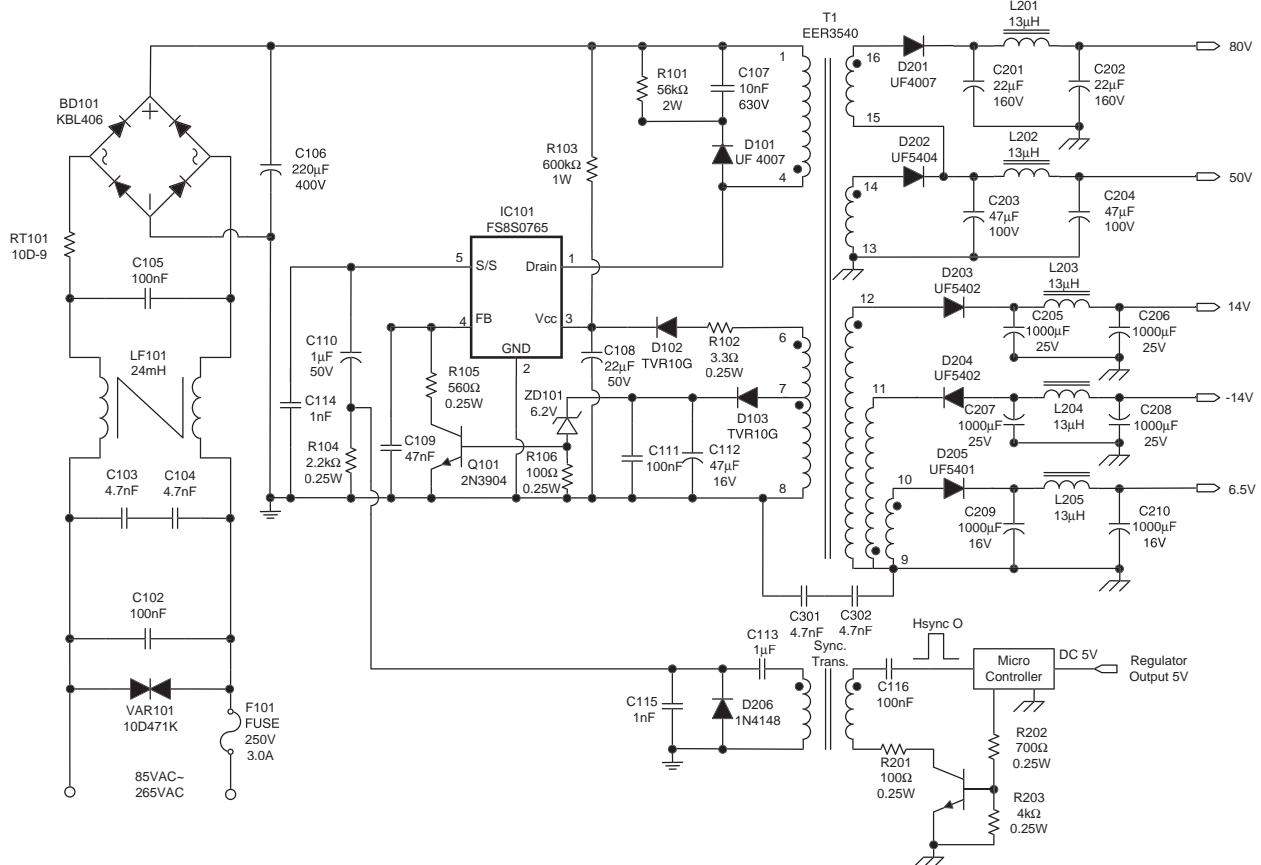

2. Transformer

2.1. Transformer Schematic Diagram

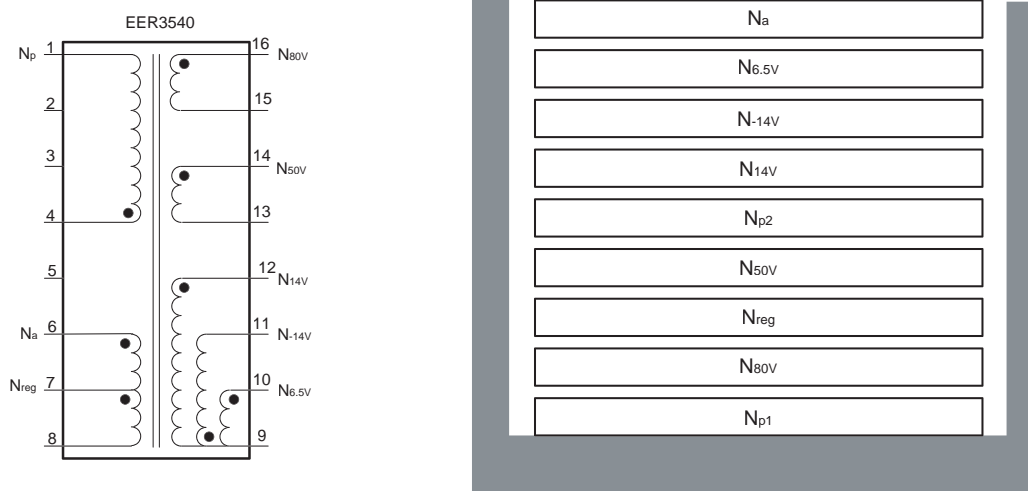

2.2. Winding Specification

| | Pin (S → F) | Wire | Turns | Winding Method |
|--|-------------|----------|-------|------------------|
| N_{p1} | 4 → 1 | 0.3Φ x 1 | 40 | Solenoid winding |
| Insulation: Polyester Tape t = 0.050mm, 2 Layers | | | | |
| N_{80V} | 16 → 15 | 0.3Φ x 1 | 10 | Center winding |
| Insulation: Polyester Tape t = 0.050mm, 2 Layers | | | | |
| N_{reg} | 7 → 8 | 0.2Φ x 1 | 3 | Solenoid winding |
| Insulation: Polyester Tape t = 0.050mm, 2 Layers | | | | |
| N_{50V} | 14 → 13 | 0.3Φ x 3 | 22 | Center winding |
| Insulation: Polyester Tape t = 0.050mm, 2 Layers | | | | |
| N_{p2} | 4 → 1 | 0.3Φ x 1 | 40 | Solenoid winding |
| Insulation: Polyester Tape t = 0.050mm, 2 Layers | | | | |
| N_{14V} | 12 → 9 | 0.3Φ x 2 | 6 | Solenoid winding |
| Insulation: Polyester Tape t = 0.050mm, 2 Layers | | | | |
| N_{-14V} | 9 → 11 | 0.3Φ x 1 | 5 | Solenoid winding |
| Insulation: Polyester Tape t = 0.050mm, 2 Layers | | | | |
| $N_{6.5V}$ | 10 → 9 | 0.3Φ x 2 | 3 | Solenoid winding |
| Insulation: Polyester Tape t = 0.050mm, 2 Layers | | | | |
| N_a | 6 → 8 | 0.2Φ x 1 | 12 | Solenoid winding |
| Outer Insulation: Polyester Tape t = 0.050mm, 2 Layers | | | | |

Core: EER3540 ($A_e = 107\text{mm}^2$)

Bobbin: EER3540

2.3. Electrical Characteristics

| | Pin | Spec. | Remark |
|------------|-----|-------------------|----------------------|
| Inductance | 1–4 | 420 μH | 300kHz, 1V |
| Leakage | 1–4 | 5 μH | Short all other pins |

TRADEMARKS

The following are registered and unregistered trademarks Fairchild Semiconductor owns or is authorized to use and is not intended to be an exhaustive list of all such trademarks.

| | | | | |
|--------------------------------------|---------------------|---------------|---------------------|-----------------|
| ACEx™ | FAST® | IntelliMAX™ | POP™ | SPM™ |
| ActiveArray™ | FASTr™ | ISOPLANAR™ | Power247™ | Stealth™ |
| Bottomless™ | FPS™ | LittleFET™ | PowerEdge™ | SuperFET™ |
| CoolFET™ | FRFET™ | MICROCOUPLER™ | PowerSaver™ | SuperSOT™-3 |
| CROSSVOLT™ | GlobalOptoisolator™ | MicroFET™ | PowerTrench® | SuperSOT™-6 |
| DOME™ | GTO™ | MicroPak™ | QFET® | SuperSOT™-8 |
| EcoSPARK™ | HiSeC™ | MICROWIRE™ | QS™ | SyncFET™ |
| E ² C MOS™ | PC™ | MSX™ | QT Optoelectronics™ | TinyLogic® |
| EnSigna™ | i-Lo™ | MSXPro™ | Quiet Series™ | TINYOPTO™ |
| FACT™ | ImpliedDisconnect™ | OCX™ | RapidConfigure™ | TruTranslation™ |
| FACT Quiet Series™ | | OCXPro™ | RapidConnect™ | UHC™ |
| Across the board. Around the world.™ | | OPTOLOGIC® | µSerDes™ | UltraFET® |
| The Power Franchise® | | OPTOPLANAR™ | SILENT SWITCHER® | UniFET™ |
| Programmable Active Droop™ | | PACMAN™ | SMART START™ | VCX™ |

DISCLAIMER

FAIRCHILD SEMICONDUCTOR RESERVES THE RIGHT TO MAKE CHANGES WITHOUT FURTHER NOTICE TO ANY PRODUCTS HEREIN TO IMPROVE RELIABILITY, FUNCTION OR DESIGN. FAIRCHILD DOES NOT ASSUME ANY LIABILITY ARISING OUT OF THE APPLICATION OR USE OF ANY PRODUCT OR CIRCUIT DESCRIBED HEREIN; NEITHER DOES IT CONVEY ANY LICENSE UNDER ITS PATENT RIGHTS, NOR THE RIGHTS OF OTHERS.

LIFE SUPPORT POLICY

FAIRCHILD'S PRODUCTS ARE NOT AUTHORIZED FOR USE AS CRITICAL COMPONENTS IN LIFE SUPPORT DEVICES OR SYSTEMS WITHOUT THE EXPRESS WRITTEN APPROVAL OF FAIRCHILD SEMICONDUCTOR CORPORATION. As used herein:

- | | |
|---|---|
| <p>1. Life support devices or systems are devices or systems which, (a) are intended for surgical implant into the body, or (b) support or sustain life, or (c) whose failure to perform when properly used in accordance with instructions for use provided in the labeling, can be reasonably expected to result in significant injury to the user.</p> | <p>2. A critical component is any component of a life support device or system whose failure to perform can be reasonably expected to cause the failure of the life support device or system, or to affect its safety or effectiveness.</p> |
|---|---|

PRODUCT STATUS DEFINITIONS

Definition of Terms

| Datasheet Identification | Product Status | Definition |
|--------------------------|------------------------|---|
| Advance Information | Formative or In Design | This datasheet contains the design specifications for product development. Specifications may change in any manner without notice. |
| Preliminary | First Production | This datasheet contains preliminary data, and supplementary data will be published at a later date. Fairchild Semiconductor reserves the right to make changes at any time without notice in order to improve design. |
| No Identification Needed | Full Production | This datasheet contains final specifications. Fairchild Semiconductor reserves the right to make changes at any time without notice in order to improve design. |
| Obsolete | Not In Production | This datasheet contains specifications on a product that has been discontinued by Fairchild semiconductor. The datasheet is printed for reference information only. |

Rev. 115